



Key Features:

- Up to 8 x10Gbps GiGE Vision links support
- PCIe Gen3 x8 Half-length card
- Up to 144 Gb image buffer
- Multi-stream support
- Camera controls and triggers
- Up to 8 re-transmit links
- Per-link LED indication on card bracket
- Flexible machine I/O:
 - 4 TTL configurable I/Os
 - 4 LVCMOS configurable I/Os
 - 2 LVDS inputs
 - 2 LVDS outputs
 - 4 opto-isolated outputs
 - 4 opto-isolated inputs
 - 4 quadrature rotary encoders
 - Integrated strobe controller
 - 4 timers
- 10GiGE Vision compliant
- Multiple Camera synchronization
- Multiple Frame Grabbers synchronization
- GUI interface
- Supporting Windows and Linux OS
- API for developing custom applications
- Plug-ins modules for MATLAB, HALCON and Labview
- Gen<i>i</i>Cam compliant
- GenTL support
- Data rates up to 10 Gbps per link
- Transfer Rate of up to 55 Gbps
- 0°C to 50°C operating environment temperature

Komodo 10GiGE™ Vision Frame Grabber

Innovative Approach

Komodo-10GiGE is a high-performance 10Gbps GiGE Vision Frame Grabber. It is capable of receiving video streams from up to 8 GiGE Vision cameras using four SFP+ 10GiGE transceivers and a single QSFP+ 40GiGE optical interface. The board offers a flexible DDR3 memory system with up to 144 Gb of memory and 128 Gbps throughput.

Intelligent Design

A high speed 8 lane Gen 3.0 PCI Express interface allows fast data transfer between optical links and computer memory. This Frame Grabber is ideally suited for industrial, defense and aerospace Machine Vision Systems and applications. This product also provides GPIO for machine control signals, such as triggers, shaft encoders, exposure control and general I/O, which can be control aside video stream acquisition.

Datasheet | Komodo™ 10GiGE Vision Frame Grabber

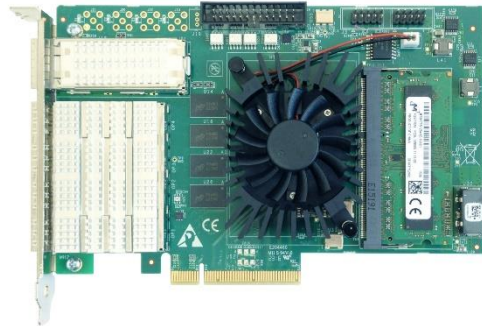

Product Name	Komodo™ 10GiGE Vision Frame Grabber
Form Factor	PCI Express card
Format	Standard profile, half length, 8-lane PCI Express card
Cooling method	Air cooling, fan-cooled heatsink
Mounting	For insertion in a standard height, 8-lane or higher, PCI Express card slot
Connectors	Ports 0 through 7 on bracket 4x SFP+ connectors 1x QSFP+ connector Internal I/O connector 26-pin 2-row 0.1" pitch pin header with shrouding for I/O lines
Dimensions	L 167.65 mm x H 111.15 mm L 6.6 in x H 4.38 in
Weight	225gr
Host bus	
Standard	PCI Express 3.0
Link width	8 lanes, 1, 2 or 4 lanes with reduced performance
Link speed	<ul style="list-style-type: none"> • 8.0 GT/s (PCIe 3.0) • 5.0 GT/s (PCIe 2.0) with reduced performance
Maximum payload size	512 bytes
DMA	<ul style="list-style-type: none"> • 32- and 64-bit • Scatter gather support • Physical address support (GPU transfers)
Peak delivery bandwidth	7,880 MB/s
Effective (sustained), delivery bandwidth	6,710 MB/s (Host PC motherboard dependent)
Power consumption	Typ. 16.8 W (3.8 W @ +3.3V, 13 W @ +12V), excluding camera and I/O power output
Camera / video inputs	
Interface standard(s)	10GiGE Vision
Status LEDs	1 Host connection status per connector 4 System status LEDs
Number of cameras	Up to 8
Number of links, per single camera	Up to 8
Synchronization between cameras	Yes
Line-scan cameras supported,	Yes
Maximum aggregated camera data transfer rate	55 Gbit/s

Supported CLHS speeds	
Number of data streams (per camera)	1 data stream per camera
Maximum stream packet size	8,192 bytes
Camera types	<ul style="list-style-type: none"> • Area-scan cameras: <ul style="list-style-type: none"> • Gray-scale and color (RGB and Bayer CFA) • Single-tap (1X-1Y) progressive-scan • Line-scan cameras:, <ul style="list-style-type: none"> • Gray-scale and color RGB
Camera pixel formats supported	Raw, Monochrome, Bayer, RGB, YUV, YCbCr and RGBA (PFNC names): <ul style="list-style-type: none"> • Raw • Mono8, Mono10, Mono12, Mono14, Mono16 • BayerXX8, BayerXX10, BayerXX12, BayerXX14, BayerXX16 where XX = GR, RG, GB, or BG • RGB8, RGB10, RGB12, RGB14, RGB16 • RGBA8, RGBA10, RGBA12, RGBA14, RGBA16 • YUV411_8, YUV411_10, YUV411_12, YUV411_14, YUV411_16 • YUV422_8, YUV422_10, YUV422_12, YUV422_14, YUV422_16 • YUV444_8, YUV444_10, YUV444_12, YUV444_14, YUV444_16 • YCbCr601_411_8, YCbCr601_411_10, YCbCr601_411_12, YCbCr601_411_14, YCbCr601_411_16 • YCbCr601_422_8, YCbCr601_422_10, YCbCr601_422_12, YCbCr601_422_14, YCbCr601_422_16 • YCbCr601_444_8, YCbCr601_444_10, YCbCr601_444_12, YCbCr601_444_14, YCbCr601_444_16
Area-scan camera control	
Trigger	Precise control of asynchronous reset cameras, with exposure control. Support of camera exposure/readout overlap. Support of triggering from encoder or timer Support of external hardware trigger, with optional delay, filtering and trigger decimation.
Strobe	Accurate control of the strobe position for strobe light sources. Support of early and late strobe pulses.
Line-scan camera control	
Scan/page trigger	Precise control of start-of-scan and end-of-scan triggers. Support of external hardware trigger, with optional delay and filtering. Support of triggering from encoder Support of infinite acquisition, without missing lines.
Line trigger	Support for quadrature motion encoders, with programmable filters, selection of acquisition direction and backward motion compensation.
Line strobe	Accurate control of the strobe position for strobe light sources.
On-board processing	
On-board memory	<ul style="list-style-type: none"> • 2 GB • Up to 16GByte SODIMM
Bayer De-Mosaic	Full 16bit resolution <ul style="list-style-type: none"> • Bilinear 3x3 • Bilinear 3x2 for linescan with gradient correction
Color Transformation	Full 16bit resolution 18bit coefficients table <ul style="list-style-type: none"> • Color space conversion • Gain and Offset
Decimation	Line skip
Additional features	Unpacking of 10-/12-/14-bit to 16-bit with justification to LSB
Frame Timestamp	64bit with 8ns precision

Data stream statistics	Measurement of: <ul style="list-style-type: none"> • Frame/Line rate • CRC Errors • Dropped frames • Received packets • Test packets
Event signaling and counting	The application software can be notified of the occurrence of various events: <ul style="list-style-type: none"> • Newly acquired buffers • Camera and Illumination control events • I/O events • Timer events • Encoder events
General Purpose Inputs and Outputs	
Number of lines	20 I/O lines: <ul style="list-style-type: none"> 2 differential inputs 2 differential outputs 4 singled-ended TTL inputs/outputs 4 singled-ended LVCTTL inputs/outputs 4 opto-isolated inputs 4 opto-isolated outputs
Usage	Any System I/O input lines can be connected to any I/O line Any I/O line can be used to decode A/B and Z signals of a motion encoder Any I/O line can generate any trigger event Any I/O line can trigger a timer
Electrical specifications	Differential lines - LVDS compatible TTL lines - 5V TTL compliant LVTTTL lines - 3.3V LVTTTL compliant Isolated lines - opto isolated lines with voltage range up to 30V
Filter control	Glitch removal filter available on all System I/O input lines Configurable filter time constants: for DIN and TTLIO lines: 50 ns, 100 ns, 200 ns, 500 ns, 1 μ s for IIN lines: 500 ns, 1 μ s, 2 μ s, 5 μ s, 10 μ s
Polarity control	Yes
Encoders	4 quadrature encoders with A/B and Z inputs 32bit position counter Forward and backward counting Position trigger support Noise filtering
Timers	8 general purpose timers Configurable delay and duration 32bit accumulator
Event reporting	64 bit system timestamp event reporting Each I/O line can generate event on configurable edge Each Timer can generate event Each encoder can generate event
Frame grabber synchronization	
Synchronization	Precise area and linscan cameras synchronization across different frame grabbers
Software	
Host PC Operating System	Microsoft Windows 7/10 32- and 64-bit versions, Linux open source driver compatible with a wide range of distributions, tested and precompiled for Ubuntu 14.04 , RedHat 6.5 , CentOS 7 32- and 64-bit versions
Buffer management	Circular buffer support Accumulation of several frames/lines to single buffer to reduce CPU load DMA Buffer filling directly to system memory
GUI	Supported for Windows and Linux OS Multi-camera display and configuration Flexible buffer queuing Image/video recording and playback

Debugging capabilities	Event logging Statistics counters
Gen<i>Cam	Support of genicam up to 2.4 Full camera and frame grabber parameters configuration
Environmental conditions	
Operating ambient air temperature	0°C to +50°C / +32°F to +122 °F
Operating ambient air humidity	10% to 90% RH non-condensing
Storage ambient air temperature	-20°C to +70°C / -4°F to +158°F
Storage ambient air humidity	10% to 90% RH non-condensing
Certifications	
Electromagnetic - EMC standards	The European Council EMC Directive 2004/108/EC The Unites States FCC rule 47 CFR 15
EMC - Emission	EN 55022:2010 Class B FCC 47 Part 15 Class B
EMC - Immunity	EN 55024:2010 Class B EN 61000-4-3 EN 61000-4-4 EN 61000-4-6
Flammability	PCB compliant with UL 94 V-0
RoHS	Compliant with the European Union Directive 2011/65/EU (ROHS2)
REACH	Compliant with the European Union Regulation No 1907/2006
WEEE	Must be disposed of separately from normal household waste and must be recycled according to local regulations
Ordering Information	KY-FGK-10G
Optional accessories	<ul style="list-style-type: none"> • GPIO Expansion bracket • DDR3 Extra memory SODIMM 2GB, 4GB, 8GB or 16GB • SFP+ optical modules • QSFP+ optical modules

Komodo 10GiGE Vision Frame Grabber HW Block Diagram

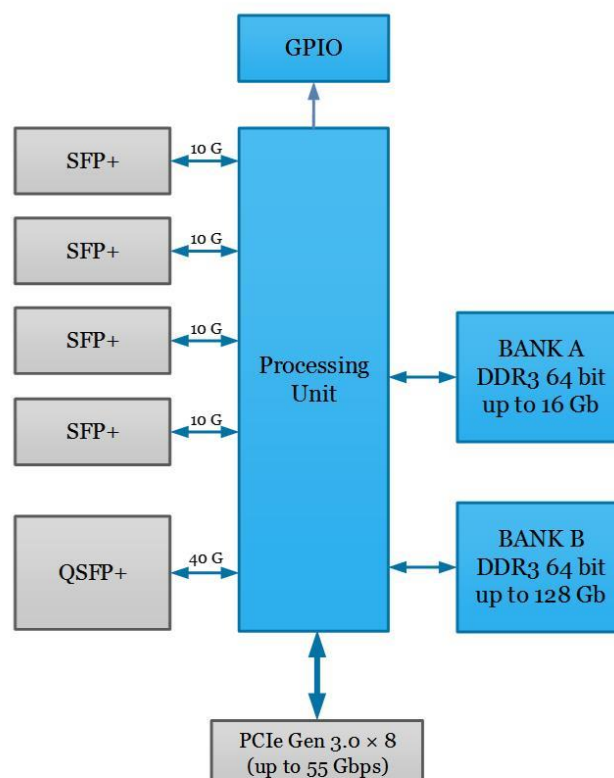

Compatibility

Supported vision standard



Supported vision libraries



Supported operating systems



Compatible with most popular machine vision libraries

KAYA Instrument strives to create and maintain compatibility and interfaces for the most common and advanced vision image processing libraries and applications. Major support is available for **MVTec Halcon**, **National Instruments LabVIEW** and **MathWorks MATLAB**.

International Distributors



Sky Blue Microsystems GmbH
Geisenhausenerstr. 18
81379 Munich, Germany
+49 89 780 2970, info@skyblue.de
www.skyblue.de



In Great Britain:
Zerif Technologies Ltd.
Winnington House, 2 Woodberry Grove
Finchley, London N12 0DR
+44 115 855 7883, info@zerif.co.uk
www.zerif.co.uk